

Fault Analysis of a Conceptual McMaster University Microgrid Design

C. Tang, S. Kauser, S.M. Gulamhusein, M. Mungroo
McMaster University
Canada

SUMMARY

New technologies in communications, protection and control, and increased penetration of distributed energy resources have contributed to the development and installation of microgrids around the world. Some of the main benefits of microgrids include improved electricity supply reliability, better power quality, better equipment protection, and reduced energy costs.

The purpose of this paper is to preliminary investigation of the fault current levels on the McMaster distribution grid (MacGrid) when under off-grid mode of operation. Fault currents play an important role in determining switching device short circuit duties as well as protection coordination of protective relays. The university campus is fed from the Burlington station of the main grid, via two 115-kV overhead transmission lines each of which terminates at a 115/13.8 kV step down transformer. The campus peak load is approximately 26 MW and the MacGrid has a 13.8 kV underground cable radial distribution network. Currently, the MacGrid has a 5.7 MW gas-fired generator at the Central Utility Plant and six 1.8-MW diesel generators located at the McMaster University Medical Centre. Moreover, McMaster is evaluating the financial benefits of installing a new 10 MW gas-fired peaking generator. Therefore, the proposed new 10 MW generator is also included in the short circuit calculation.

The fault analysis presented in this paper follows the ANSI approach and covers both the grid-connected and the island mode of operation. Fault analysis results were first obtained by hand calculations using a reduced network model with all feeder cables and resistance values ignored, except the grounding resistors which are important in unbalanced fault calculations. To verify the hand calculations, ETAP simulation software was run on a more detailed network model. Three-phase and single-line-to-ground fault currents were calculated for the MacGrid with different combinations of grid ties and synchronous generators in service.

The paper will first provide a high-level description of the mathematical formulation of power system fault current analysis based on symmetrical components. It then presents the modelling details for the construction of positive, negative and zero sequence networks of the MacGrid. Fault analysis results are then given for both 3-phase and single-line-to-ground faults at the main 13.8 kV distribution bus of the MacGrid.

The fault analysis results from hand calculations agree well with the ETAP simulation results. The paper has demonstrated that for a 3-phase fault at the main 13.8 kV distribution bus, the total fault

cktang@mcmaster.ca

current for grid-connected and off-grid modes can be easily calculated, by getting the algebraic sum of the fault current contribution from each source. It also confirms that under off-grid mode of operation, the 3-phase fault currents are significantly reduced when compared to those under grid-connected mode of operation. Furthermore, the paper illustrates that the SLG fault currents are highly dependent on the grounding method of the synchronous generators. SLG fault currents were provided with generators solidly grounded, ungrounded, and grounded through high impedance. To facilitate both grid-connected and off-grid mode of operation, future research work is required on generator grounding design and protection coordination of protective relays.

KEYWORDS

Fault analysis, microgrid design, symmetrical components

1.0 INTRODUCTION

Microgrids are local power distribution networks containing a combination of loads and distributed energy resources, that can operate in either the grid-connected or off-grid mode. Microgrids provide a mechanism for controlling local loads and generation resources, thus offering opportunities for improved power grid reliability and reduced electricity costs. When a major disturbance occurs on the main transmission grid, a microgrid can still operate in the off-grid mode and continue to serve its load customers.

McMaster University has a student population of more than 33000 and its main campus is comprised of about 300 acres of property in Hamilton, Ontario. The university campus is fed from the main grid via two 115-kV overhead transmission lines. The campus has a peak load of approximately 26 MW connected to a 13.8 kV underground distribution system. Currently, the campus has a 5.7 MW gas-fired generator located at the Central Utility Plant, and six 1.8 MW diesel generators located at the McMaster University Medical Centre (MUMC). Furthermore, McMaster University is evaluating the merits of acquiring a new 10 MW gas-fired peaking generator. If approved, the McMaster distribution grid (MacGrid) will have 8 generators with a total generating capacity of approximately 26 MW. When disconnected from the main grid, the MacGrid still has enough generation to supply its own load, hence capable of form a microgrid system.

This paper compares the fault current levels on the MacGrid under grid-connected and off-grid (islanded) mode of operation. Calculation of fault currents is essential for assessing circuit breaker duties and performing protection coordination of protective devices. Calculation of short circuit currents in industrial and commercial power systems is fully described in IEEE standard 551 [1]. Reference [2] provides an application guide for AC high-voltage circuit breakers rated on symmetrical current basis. By following the ANSI approach, the authors have calculated the fault currents for the MacGrid in two ways. First, fault analysis was done by hand calculations with a reduced network. Then ETAP simulation software was run on a more detailed network to verify the hand calculations. This work will set the stage for future research work on protection coordination design for the MacGrid operated as a standalone microgrid.

Section 2 describes the mathematical formulation of fault analysis. Section 3 describe the modelling requirements of the MacGrid for the purpose of the fault analysis. Section 4 presents the fault analysis results for different combinations of grid ties and synchronous generators in service. Finally the conclusions are summarized in Section 5.

2.0 MATHEMATICAL FORMULATION OF FAULT ANALYSIS

Power system fault analysis is accomplished by the use of symmetrical components. A detailed description of fault analysis can be found in [3, 4]. This section briefly summarizes the mathematical formulation of power system fault analysis.

2.1 Symmetrical Components

Any set of unbalanced phase quantities (e.g., V_a , V_b and V_c) can be converted into three sets of balanced sequence components: positive sequence (V_{a1} , V_{b1} and V_{c1}), negative sequence (V_{a2} , V_{b2} and V_{c2}), and zero sequence (V_{a0} , V_{b0} and V_{c0}) components. The following two matrix equations can be used to perform transformation between phase components and symmetrical components back and forth. In these matrix equations, V_1 , V_2 and V_0 represent the positive, negative, and zero sequence of phase A.

$$\begin{bmatrix} V_a \\ V_b \\ V_c \end{bmatrix} = \begin{bmatrix} 1 & 1 & 1 \\ a^2 & a & 1 \\ a & a^2 & 1 \end{bmatrix} \begin{bmatrix} V_1 \\ V_2 \\ V_0 \end{bmatrix}; \quad \begin{bmatrix} V_1 \\ V_2 \\ V_0 \end{bmatrix} = \frac{1}{3} \begin{bmatrix} 1 & a & a^2 \\ 1 & a^2 & a \\ 1 & 1 & 1 \end{bmatrix} \begin{bmatrix} V_a \\ V_b \\ V_c \end{bmatrix}$$

2.2 Connection of Sequence Networks

According to the symmetrical component theory, positive/negative/zero sequence currents only flow in the corresponding positive/negative/zero sequence networks. The three sequence networks are decoupled from each other except at the fault point. To calculate the fault currents for a balanced 3-phase fault, only the positive sequence network is needed. For a SLG fault, the three sequence networks (positive, negative, and zero) are needed and connected in series, resulting in I_1 , I_2 and I_0 being all equal. In this paper, only 3-phase and SLG fault currents were considered.

3.0 MODELLING OF MCMaster DISTRIBUTION GRID

The MacGrid consists 13.8 kV underground radial circuits C1 to C10, as shown in Fig. 1. Each circuit has two parallel feeders emanating from the indoor 13.8 kV distribution bus located at the Central Utility Plant, with one feeder in service at any given time and the other as a backup. The distribution bus is divided into three bus sections (Q1, Q2, and Q3) connected by bus tie circuit breakers Q1Q2 and Q2Q3. The MacGrid is connected to the main grid via two 115 kV overhead transmission lines.

Currently the MacGrid has a 5.7 MW gas-fired generator rated connected directly to the Q1 bus through a 50-foot cable. Circuit 6 supplies power to the McMaster University Medical Centre (MUMC) which has six 1.8 MW diesel generators. In this paper, a proposed 10 MW gas-fired peaking generator is also included in the short circuit calculation.

Figure 1 : MacGrid Single Line Diagram

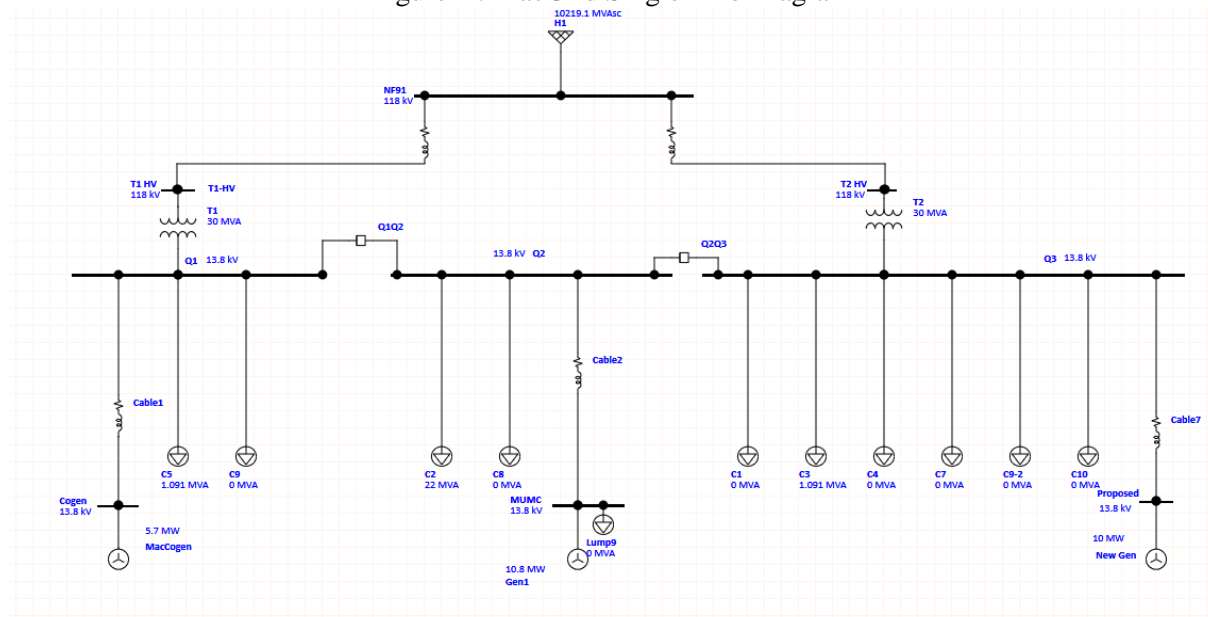

As shown in Figure 1, the MacGrid is fed from the Burlington 115 kV station through two overhead transmission lines B3 and B4, which are connected to McMaster transformers T1 and T2 respectively. To facilitate hand calculations, the MacGrid network model was reduced to a simple equivalent circuit as shown in Figure 2. Impedance values in pu for the circuit elements are provided in Table 1, on 100 MVA and 13.8 kV base, except for generators whose MVA base values are equal to the generator MVA ratings which are 6.7 MVA, 11.8 MVA and 6 x 2.1 MVA for GG1, GG2 and DG6 respectively.

Table 1: Equipment Impedance Values in PU

	R1	X1	R0	X0
Utility Feed U1 and U2	0.00449	0.03527	0.02647	0.10801
Transformer T1 and T2	0.0167	0.3933	0.0167	0.3933
All generators	0.01	0.19	0.01	0.07

The reduced network for the MacGrid is shown in Fig. 2, with all feeder impedances ignored. Generator DG6 is the equivalent of six diesel generators. The three 13.8 kV bus sections (Q1, Q2 and Q3) can be combined into one single bus. In this paper, fault current contributions from induction motors are ignored, and AC and DC fault current decay is also ignored.

Figure 2: Simplified MacGrid Network

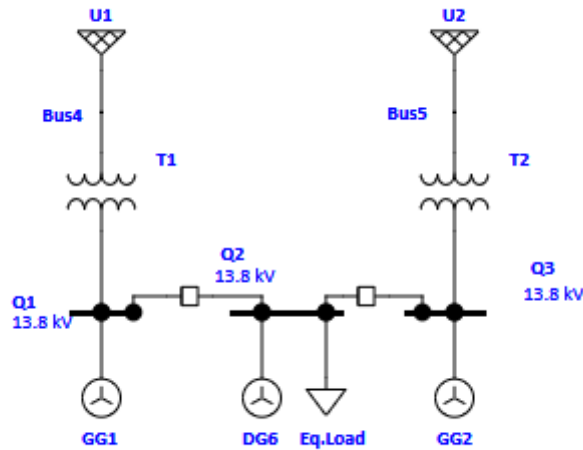

4.0 FAULT ANALYSIS RESULTS

This section presents the symmetrical fault current calculations at the main distribution bus (Q1, Q2 and Q3) under both the grid mode and island mode configuration. Hand calculations were performed first, followed by ETAP simulations. Note that for 100 MVA and 13.8 kV base, the current base (I_b) is equal to 4.18 kA. In this preliminary fault analysis, short circuit current contributions by induction motors were ignored. AC and DC fault current decay was also ignored.

4.1 Three-Phase Fault

For a 3-phase fault at Q1 or Q2 or Q3, the fault current contribution from each source can be calculated by applying Ohm's law. Table 2 provides the fault current from each source based on hand calculations as well as ETAP simulations.

Table 1: Three-Phase Fault: Comparison between Hand Calculations and ETAP Results

Fault Current Source	By Hand (kA)	By ETAP (kA)
Utility Feed U1 or U2	9.75	9.66
GG1	1.5	1.474
GG2	2.6	2.585
DG6	2.8	2.757

Knowing the operating status of each current source, the total fault current at the Q1 or Q2 or Q3 can be summed algebraically. For example, if U1, U2 and GG1 are in service, then the total fault current is equal to $9.75 \text{ kA} + 9.75 \text{ kA} + 1.5 \text{ kA} = 21 \text{ kA}$, using hand calculation results.

Table 2 presents the total fault current at Q1 (Q2 or Q3) for different operating configurations, varying from grid mode to off-grid mode of operation. Under grid mode, results are given for one grid tie in service and both grid tie in service. Table 2 illustrates that the fault currents under off-grid mode are

much less than those under grid-mode operation, requiring protection coordination of protective relays to be reviewed.

Table 2: Fault Currents for Different Operating Configurations

Configuration - Grid connected	$I_{f,sym}$ (kA)		Off-Grid Mode	$I_{f,sym}$ (kA)
	both ties	one tie		
Grid only	19.5	9.75		
Grid + GG1	21.0	11.25	GG1	1.5
Grid + GG2	22.1	12.35	GG2	2.6
Grid + 6DGs	22.3	12.55	6DGs	2.8
Grid + GG1 + GG2	23.6	13.85	GG1 + GG2	4.1
Grid + GG1 + 6 DGs	23.8	14.05	GG1 + 6DGs	4.3
Grid + GG2 + 6 DGs	24.9	15.15	GG2 + 6DGs	5.4
Grid + GG1 + GG2 + 6 DGs	26.4	16.65	GG1 + GG2 + 6DGs	6.9

4.2 Single-Line-to-Ground Fault

For a SLG fault, all three sequence networks are involved and the transformer representation in the zero sequence network depends on the transformer winding configurations and the grounding methods used. The grid tie transformers T1 and T2 are connected in delta (Δ) on the 115 kV side and in wye (Y) on the 13.8 kV side, grounded through a 4Ω grounding resistor. Generator representation in the zero sequence network also depends on the grounding of the generator neutral, which can be solidly grounded, high impedance grounded, low impedance grounded, or ungrounded. Note that in the MacGrid, all synchronous generators are connected to the 13.8 kV distribution bus (Q1, Q2 or Q3) without any step up transformers. Figure 3 illustrate the transformer and generator representations in the zero sequence network.

Figure3: Representation of Transformer and Generator in Zero Sequence Network



4.2.1 Generators Solidly Grounded

Assuming the neutral of each generator is solidly grounded and for a SLG fault on phase A of the 13.8 kV distribution bus (Q1, Q2 or Q3), fault currents were calculated for three configurations as presented in Table 3.

Table 3: SLG Fault Currents with Generator Neutral Solidly Grounded

	SLG Fault Current (kA)	
	By Hand	By ETAP
Utility Feed		
U1	1.945	1.938
GG1 only	1.900	1.904
U1 + GG1	7.100	7.189

Table 3 shows that the law of superposition does not apply to SLG fault current calculations, due to nature of the ground paths. With only U1 in service, the fault current is 1.945kA. With only generator

GG1 in service, the fault current is 1.9 kA. However, the fault current is much higher with both U1 and GG1 in service, at 7.1 kA.

4.2.2 Generators with Ungrounded Neutral

When the neutral of each generator is ungrounded, the SLG fault current only comes from the grid tie transformers T1 and T2, as shown in Table 4. Although only generator GG1 is included in Table 4, fault current contribution from any in-service generator is also zero since its neutral is open circuited.

Table 4: SLG Fault Currents with Generator Neutral Ungrounded

	SLG Fault Current (kA)	
	By Hand	By ETAP
Utility Feed U1	1.945	1.938
U1 + U2	3.890	3.896
GG1 only	0.000	0.000
U1 + GG1	1.945	1.945

4.2.3 Generators with High Impedance Grounding

In the last scenario, the neutral of each generator is grounded through a 160 Ω grounding resistor. Table 5 presents the fault currents for different configurations, obtained from ETAP only. In this scenario, the SLG fault currents are contributed by the grid tie transformers T1 and T2 only. Fault current contributions from the high-impedance grounded generators are minimal.

Table 5: SLG Fault Currents with Generator Neutral Grounded through 160Ω Resistor

	SLG Fault Current (kA)	
	By Hand	By ETAP
Utility Feed		
U1	N/A	1.938
U1 + U2	N/A	3.896
GG1 only	N/A	0.050
GG2 only	N/A	0.050
DGs only	N/A	6 x 0.05
U1 + GG1	N/A	1.986
U1+U2+GG1	N/A	3.924

5.0 CONCLUSION

Three-phase and SLG fault currents have been calculated for the MacGrid under grid-connected and off-grid modes of operation. The paper has demonstrated that for a 3-phase fault at the main 13.8 kV distribution bus, the total fault current for grid-connected and off-grid modes can be easily calculated, by getting the algebraic sum of the fault current contribution from each source. It also confirms that under off-grid mode of operation, the 3-phase fault currents are significantly reduced when compared to those under grid-connected mode of operation. Furthermore, the paper illustrates that the SLG fault currents are highly dependent on the grounding method of the synchronous generators. SLG fault currents were provided with generators solidly grounded, ungrounded, and grounded through high impedance. To facilitate both grid-connected and off-grid mode of operation, future research work is required on generator grounding design and protection coordination of protective relays.

ACKNOWLEDGEMENT

The authors wish to express their sincere thanks to Mr. Joe Emberson and Mr. Alvin Baldovino of McMaster Central Services for their valuable support to this research work.

BIBLIOGRAPHY

- [1] IEEE Standard 551-2006, IEEE Recommended Practice for Calculating Short-Circuit Currents in Industrial and Commercial Power Systems
- [2] IEEE Standard C37.010-1999 (R2005), IEEE Application Guide for AC High-Voltage Circuit Breakers Rated on a Symmetrical Current Basis
- [3] William D. Stevenson, "Elements of Power System Analysis," 4th Ed., McGraw Hill, 1982
- [4] Electrical Transmission and Distribution Reference Book, Westinghouse, 1964